

NO DIG *Equipment*

The Trenchless Technology Specialists



Vacuum Excavator VM400

Three Stage filtration system

Our VM range of Vacuum Excavators are incorporated with a three stage filtration system, including a cyclonic dust separation unit, with a 5 micron washable poly filter element. This three stage filtration system is a very efficient dust separation process, which minimises the frequency of filter cleaning.

Powerful positive displacement blower

High level continuous flow vacuum pump, without the need to prime or need for the inlet hose to be submerged. Ideal for potholing, service locating, mud removal or general cleaning.

Fully Galvanised Waste Bowl

Our VM400 incorporates a fully galvanised waste bowl, improving durability and minimising rust, adding years to the life of our Vacuum Excavators and offers the best protection against harsh conditions.

High pressure water system

Set at 2500psi, these small yet powerful triplex piston pumps enable you to quickly and safely pothole to determine the exact location of underground utilities and drilling equipment.

What type of work can you do with a Vacuum Excavator VM400?

- Cleaning Telstra pits
- Underground service locating
- Clean up construction sites
- Install fence posts
- Live gas pipe maintenance
- Live sewer pipe maintenance
- Installing NBN optical fibre through asbestos pipe
- and much more

VM 400 Vacuum Excavation Machines include;

- Hydraulic tipping waste bowl for easy dumping
- 23.5Hp Kohler Petrol Engine
- 3" dia Vacuum Suction Hose x 7m long
- 400 Litre Spoil Tank & 200 Litre built in Water Tank
- 550cfm Blower, producing ultra efficient vacuum
- 2500psi High Pressure Triplex Water Pump



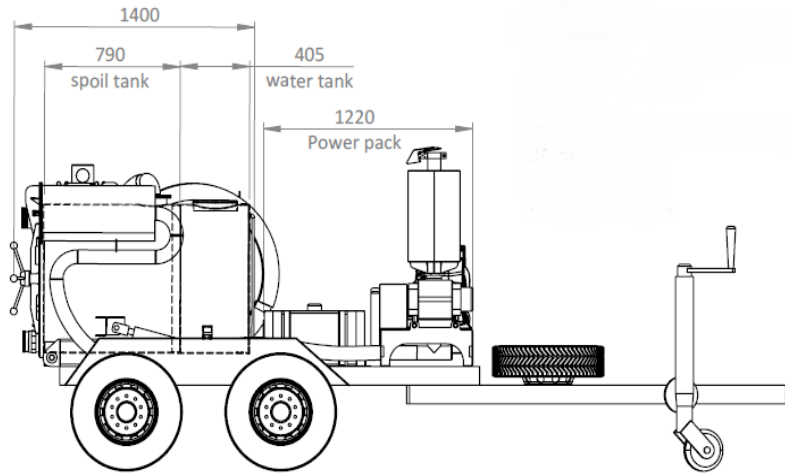
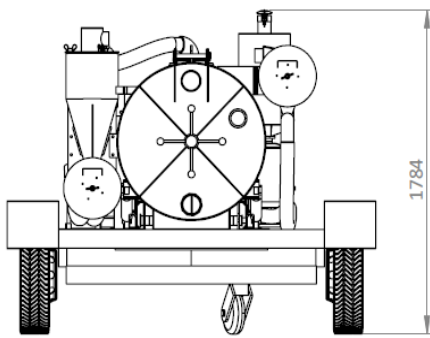
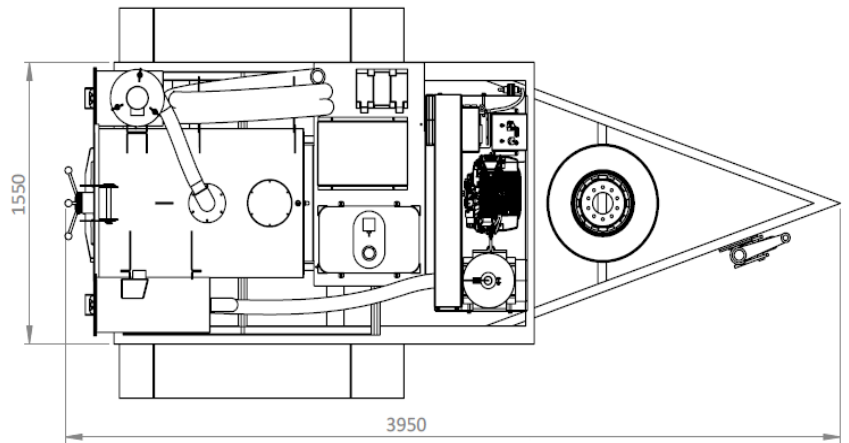
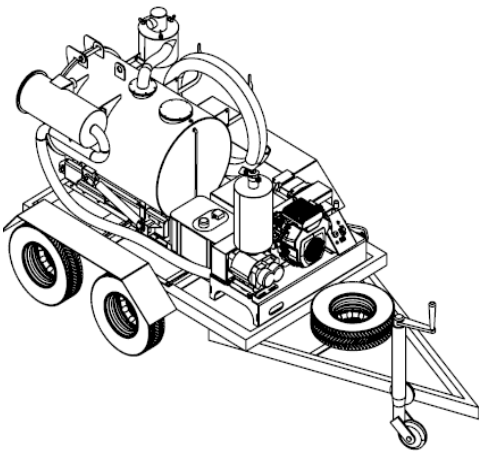

VM500 Vacuum Excavator

Vacuum System	550 CFM blower, c/w- 3" dia hose (318mm -15"Hg)
Petrol Engine	23.5 Hp Kohler Command Pro CH730
Spoil Tank	400 Litre, with hydraulic tilt
High Pressure Water Pump	2500psi
Clean Water Tank	200 Litre
Dry weight (excluding Trailer)	790 kg

Optional Extras

Trailer Mount	2T (towable by any ute) (350kg)
Skid Frame	c/w- forklifting points
Double Jet Digging Wand	6.5" Ø (165 mm) head
Hose Reel	15m Retractable



NO DIG *Equipment*

The Trenchless Technology Specialists



NO DIG *Equipment*

The Trenchless Technology Specialists

Address: 15 Wildfire Rd, Maddington WA 6109

Postal: PO Box 2, Maddington WA 6989

Ph : 08 9493 0642

Fx : 08 9493 0672

www.NoDigEquipment.com.au

sales@NoDigEquipment.com